

◆ Session II. INERTIAL SYSTEMS AND SENSORS ◆

HIGH-PRECISION FIBER OPTICAL GYROSCOPE WITH EXTENDED DYNAMIC RANGE

Yu.N.Korkishko<sup>1</sup>, V.A.Fedorov<sup>2</sup>, V.E.Prilutskiy<sup>3</sup>, V.G.Ponomarev<sup>4</sup>, I.V.Morev<sup>5</sup>, D.V.Obukhovich<sup>6</sup>,  
S.V.Prilutskiy<sup>7</sup>, S.M.Kostritskiy<sup>8</sup>, I.V.Fedorov<sup>9</sup>, A.I.Zuev<sup>10</sup>, V.K.Varnakov<sup>11</sup>

Optolink RPC LLC, 124489, Moscow, Zelenograd, Sosnovaya alleya, Building 6A, Str.2  
Russia, Tel: +7 495 6631760, Fax: +7 495 6631761, e-mail: opto@optolink.ru

**Abstract**

**Key words:** fiber-optic gyroscopes, dynamic range, scale factor stability

*At present time fiber-optic gyroscopes (FOGs) with closed-loop feedback scheme of operation are becoming widely used in inertial navigation systems. One of the main restrictions on FOG usage in the applications of inertial navigation is the limited range of measured angular rate (dynamic range). In this paper we present the results of the new high-precision FOG SRS-1001 development and test results. SRS-1001 FOG, which is the modification of serial SRS-1000 FOG, allows to overcome the observed restrictions and shows the extended dynamic range of 550 °/s, compared with the dynamic range of 90 °/s for the standard SRS-1000. Furthermore, SRS-1001 has the potential of further dynamic range increase up to 1000 °/s with the retention of high scale factor stability in overall measurement range.*

At present time fiber-optic gyroscopes (FOGs) with closed-loop feedback scheme of operation are becoming widely used in inertial navigation complexes [1-2]. In FOGs with closed-loop scheme the feedback mechanism keeps the zero signal level by compensating the Sagnac phase shift with additional phase counter-shift. The value of the phase counter-shift allows one to obtain information about the angular rate of the device rotation.

One of the serious restrictions on FOG applications in inertial navigation comes from their restricted angular rate measurement range. For serially produced precision FOG SRS-1000, precision class 0.005°/h, with fiber coil length and diameter 1000m and 140mm, respectively, the angular rate measurement range (dynamic range) comprises 90°/s. The rotation rate sign keeping range for the same device is 180°/s. For various applications that need both the precision and the correct measurement of high rotation rates up to 300°/s and even more, the need for SRS-1000 dynamic range extension is evident.

In this paper we present the results for new FOG SRS-1001, designed on the basis of serial SRS-1000, in which the described restrictions are overcome.

---

<sup>1</sup> Dr.Phys & Math. Sc., Professor, General Director.

<sup>2</sup> Dr.Phys & Math. Sc., Professor, Technical Director.

<sup>3</sup> Director of Saratov branch.

<sup>4</sup> PhD in Tech.Sc., Chief Designer, Technical Director of Saratov branch.

<sup>5</sup> Principal Engineer, Chief of group.

<sup>6</sup> Principal Engineer.

<sup>7</sup> Principal Engineer.

<sup>8</sup> Dr.Phys & Math. Sc., Dozent, Technical Director of Zelenograd branch.

<sup>9</sup> PhD student, Engineer.

<sup>10</sup> Director of Arzamas branch.

<sup>11</sup> Technical Director of Arzamas branch.

All FOGs produced by LLC RPC “Optolink” are made in so-called minimum configuration with digital signal processing (DSP) [3-11]. Minimum configuration ensures the reciprocity of optical paths for two beams counter-propagating in a fiber loop.

Structural scheme of single-axis FOGs with DSP is represented in Fig. 1. FOGs consist of one light source with central wavelength 1550 nm, one photodetectors, one fiber splitter (1:1) to divide the light wave into two parts, one ring interferometer to sense angular rate, and signal processing circuits. Ring interferometer consists of a multifunction integrated optic chip (MIOC) and polarization maintaining (PM) fiber coil with the length of 1000 meters (for SRS-1000), also produced by Optolink. The MIOC is a three-port integrated optical chip fabricated at lithium niobate wafer which executes three functions [3]. DSP generates voltage for “sawtooth” light modulation in order to compensate Sagnac phase shift and to make fixed phase shift  $\pi/2$  between counter-propagating waves using additional modulation. As a result, each channel is operating in closed-loop regime [4-11].

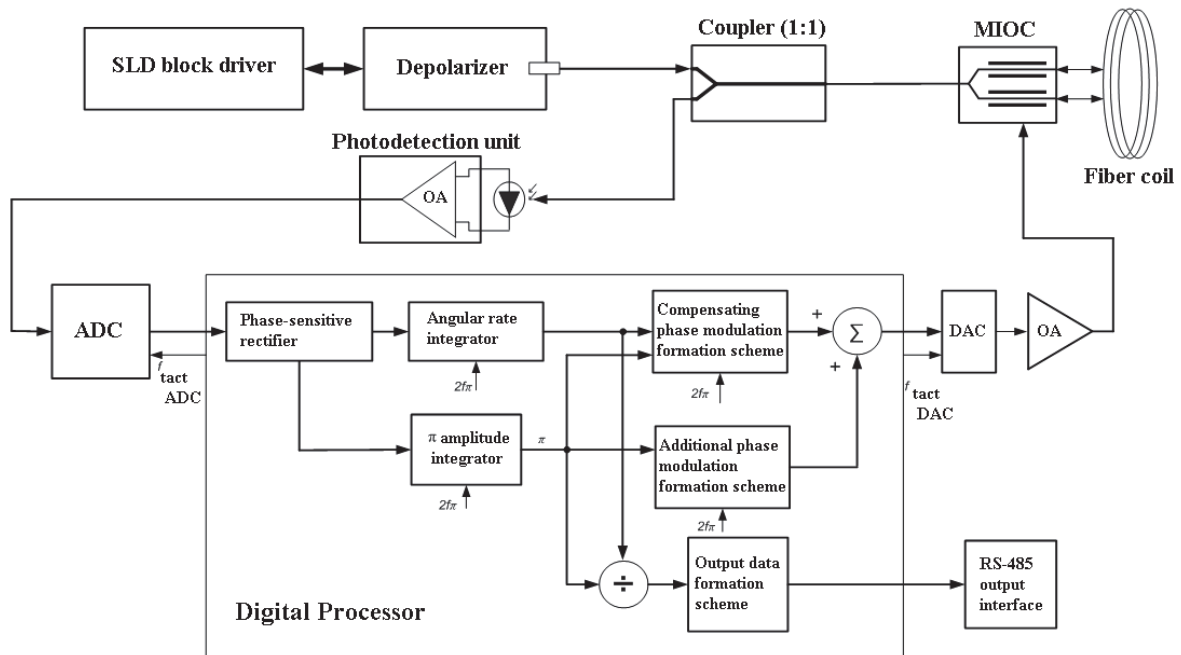

Fig. 1. FOG SRS-1000 structural scheme:

SLD – light source, superluminescent light emitting diode; MIOC – multifunctional integrated optic chip; OA – operational amplifier, ADC – analog-to-digital converter, DAC – digital-to-analog converter, RS-485 – serial interface

SRS-1001 utilizes the scheme that includes closed-loop feedback scheme for rotation rate measurement. The output rotation rate is proportion to the incline angle of applied compensating phase modulation, the amplitude of which is kept at  $2\pi$  rad value.

It is widely known that the dependence of the light intensity at the photodiode on the rotation rate of the fiber coil shows cosine nature, however, the number of periods could be exceedingly large. Standing at the point, corresponding to the Sagnac phase shift of  $2\pi$  rad (as in the case of FOG switch on in conditions of rotation with the rate, making the compensation phase shift around  $2\pi$  rad), FOG will measure the value  $\Omega_{\Delta\varphi \text{ rad}}$ , but not the correct rotation rate value  $\Omega_{2\pi} + \Omega_{\Delta\varphi \text{ rad}}$  (Fig. 2).

The value of rotation rate  $\Omega_{2\pi}$  is calculated using the compensating modulation phase amplitude. Thus, in order to measure the true rotation rate, one needs to identify the half-period number in which the Sagnac phase shift is located.

At the first stage, we developed the processing scheme that allows to measure angular rate more than  $1000^\circ/\text{s}$  on condition that FOG is switched on at rates lower than  $90^\circ/\text{s}$ . It works the following way: the scheme automatically resets the integrator, changes the sign on the input of the integrator, and adds on the output the value of angular rate  $\Omega_{\pi}$  in case of reaching the angular rate corresponding to phase shift multiple to  $\pi$  rad. The scheme of the device corresponding to this version is displayed in Fig. 3.

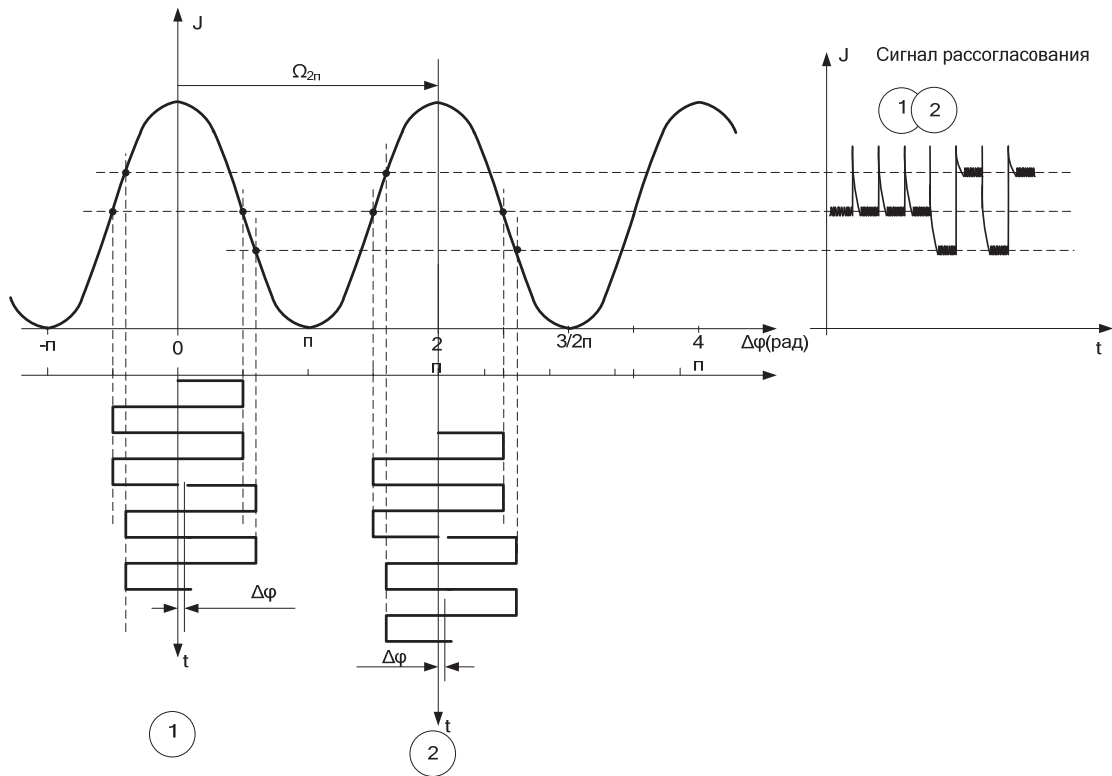

Fig. 2. Scheme of FOG output signal formation

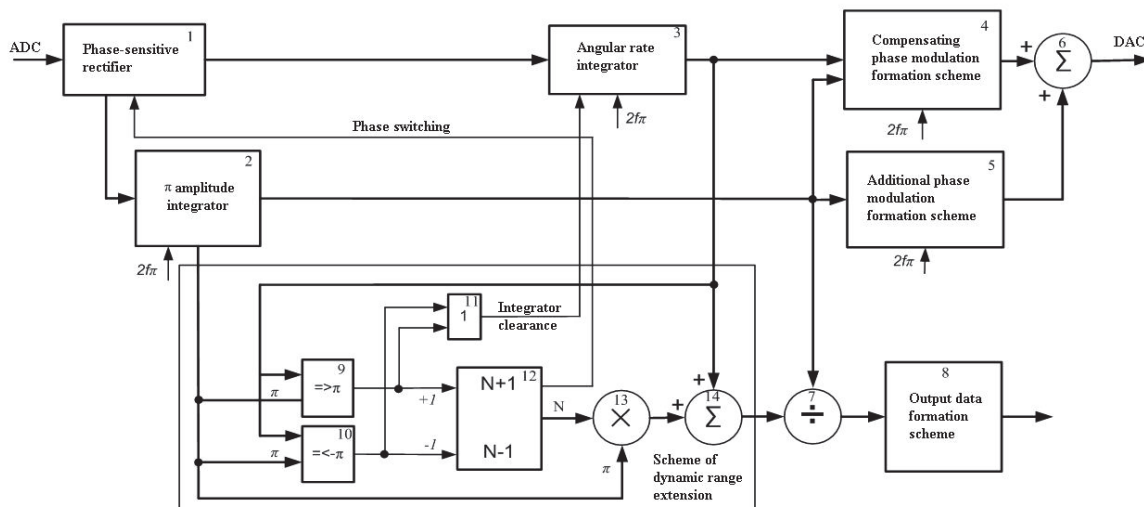

Fig. 3. FOG digital processing scheme with extended dynamic range:

- 6 – summator for phase modulation code formation, 7 – divisor of angular rate on compensating phase modulation code, 9, 10 – comparators, 11 - scheme «OR», 12 – half-period counter, 13 - multiplier, 14 – adder

*The description for the operation of dynamic range extension scheme is provided below:*

Code, proportional to the angular rate of device rotation, comes from angular rate integrator (3) and proceeds to the scheme of dynamic range extension into comparators (9), (10) and adder (14).

Trigger thresholds for comparators (9), (10) are formed using the code obtained from the compensating phase modulation amplitude integrator(2). The code corresponds to the value of angular rate that produces the Sagnac phase shift in the interferometer equal to  $\pi$  rad.

Comparator (9) is only for positive values of rotation rates, obtained from angular rate integrator(3); comparator (10) – only for negative values. In case of reaching the angular rate that corresponds to the phase shift equal to  $\pi$  rad ( $\pi$ -phase-shift angular rate) or more, comparator (9) sends the signal of increasing by 1 the counter of  $\pi$ -rad-transitions number (half-period counter) (12) value . In case of reaching the angular rate that corresponds to the phase shift equal to  $-\pi$  rad or less, comparator (10) sends the signal of decreasing by 1 the value of half-period counter (12).

Signals from comparators (9), (10) are also sent to scheme «OR» (11), in which the angular rate integrator clearance signal (3) is formed. Half-period counter (12) forms the signed value N that corresponds to the sum of comparators (9) and (10) signals. In case of an odd value of half-period counter (12) the phase switch signal is produced in phase-sensitive rectifier (1).

Half-period counter value is sent to multiplier (13), in which it is multiplied by the value of  $\pi$ -phase-shift angular rate. Multiplication result is send into the adder (14), where it is added to the angular rate value from angular rate integrator (3). The resulting value from the adder goes to the divisor (7) for correction on amplitude  $\pi$ .

FOG SRS-1000 tests with such processing scheme showed the scale factor linearity retention up to angular rates  $\pm 1000^\circ/s$  with reliable measurement range switching. The results for the developed FOG SRS-1001 with extended dynamic range are presented in Figures 4-6. SRS-1001 output signal during the stepwise angular rate change in range 10-540 $^\circ/s$  (in single launch) is shown in Fig. 4. Calculated results of two produced and tested SRS-1001 devices in similar launches are shown in Fig. 5. These results confirm high scale factor stability (less than 50 ppm) in overall extended angular rate measurement range (up to 550  $^\circ/s$ ).

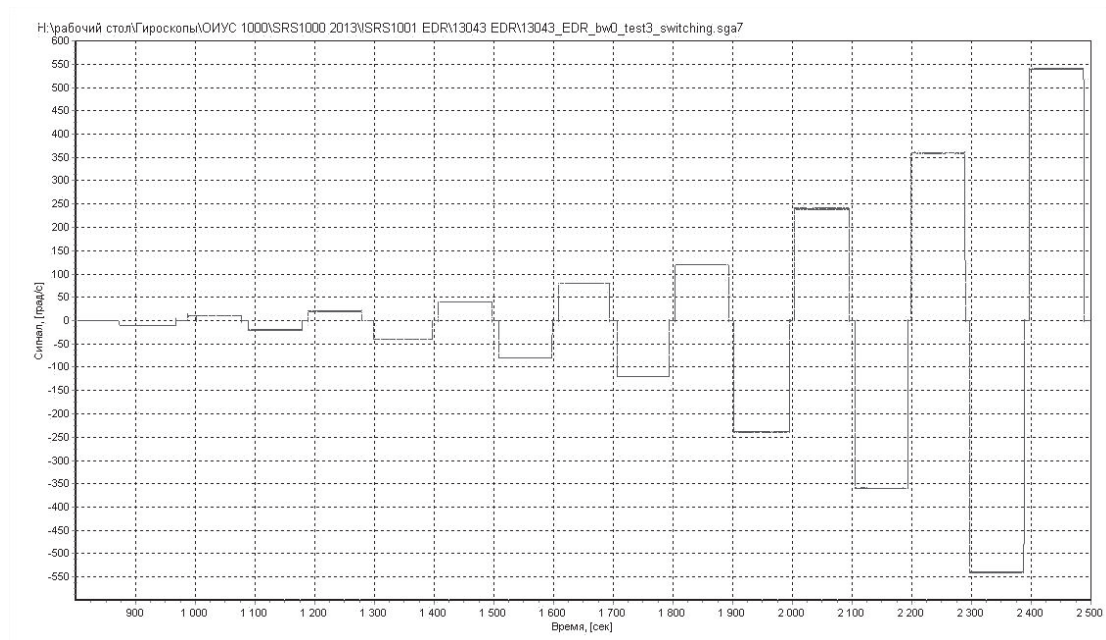

Fig. 4. SRS-1001 output signal during the stepwise angular rate change in range 10-540 $^\circ/s$  in single launch

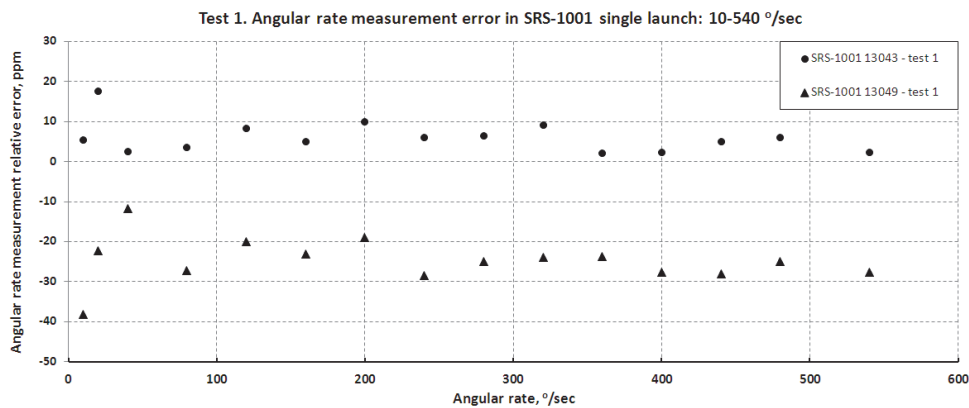

Fig. 5. Angular rate measurement relative error of two SRS-1001 devices during the stepwise angular rate change in range 10-540 $^\circ/s$  in single launch

Fig. 6 shows the results of testing SRS-1001 units in single launch on the border of two octaves ( $90^\circ/\text{s}$ ) – results confirm that the measurement on the border of two octaves does not affect SRS-1001 parameters, no difference in characteristics is observed.

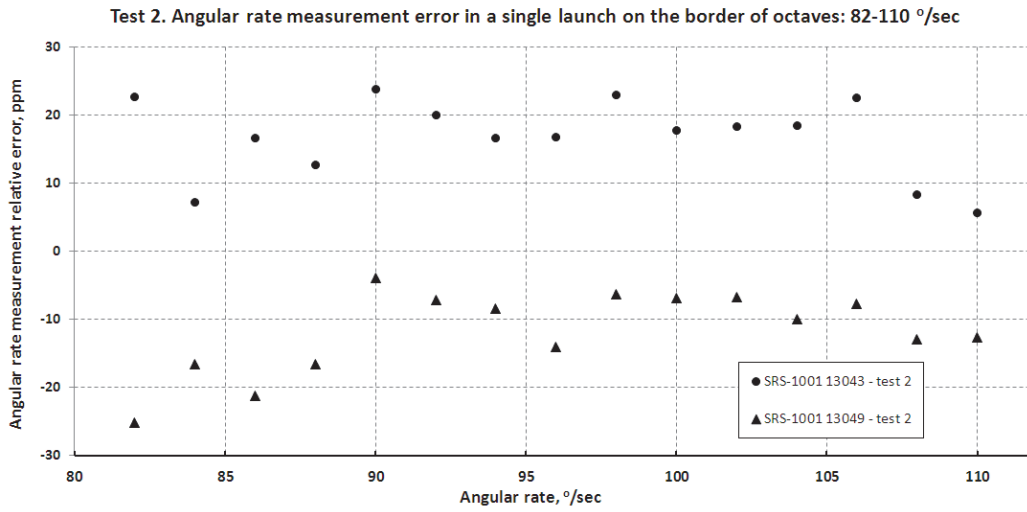

Fig. 6. Angular rate measurement relative error in a single launch on the border of two octaves

Nevertheless, there remained a problem with angular rates correct measurement in conditions of the FOG switch on at rates higher than  $90^\circ/\text{s}$ .

In order to solve this problem, we developed fiber-optic gyroscope SRS-1001, created on the basis of FOG SRS-1000 optical scheme. For the identification of the half-period number in which Sagnac phase shift is located, SRS-1001 utilizes micromechanical (MEMS) gyro with angular rate measurement range more than  $1000^\circ/\text{s}$ . FOG digital processing scheme with MEMS gyroscope correction is shown in Fig. 7.

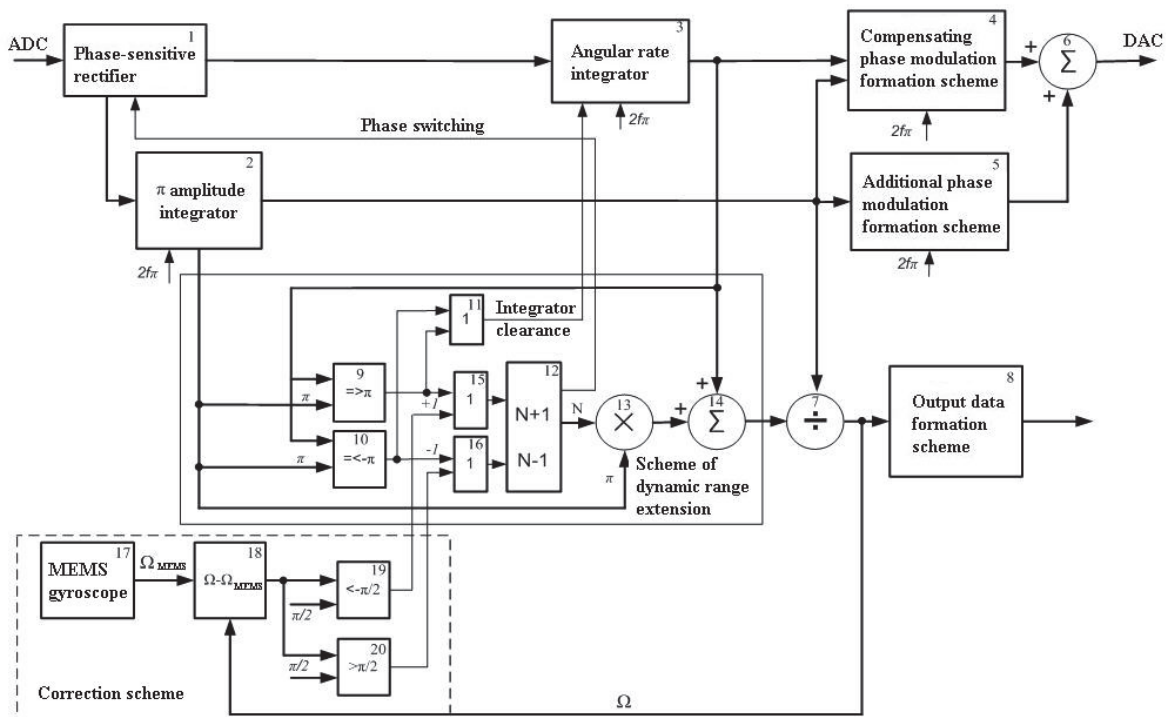

Fig. 7. FOG digital processing scheme with MEMS gyroscope correction and extended dynamic range

The description for the operation of dynamic range extension scheme with MEMS correction is provided below:

Angular rate value, measured with MEMS gyroscope (17), is subtracted in the scheme of subtraction (18) from the angular rate value measured by FOG. The obtained value of difference is compared in comparators (19), (20) with the angular rate value that corresponds to  $\pi/2$  phase shift. If the difference is less than  $-\pi/2$  rad, the signal is sent to increase by 1 the value of half-period counter (12), which passes through scheme «OR» (15). If the difference is greater than  $\pi/2$  rad, the signal is sent to decrease by 1 the value of half-period counter (12), which passes through scheme «OR» (16).

The results of SRS-1001 angular rate measurement error calculation for the tests with SRS-1001 switching on in rotation, presented in Figure 8, show the correctness of the developed scheme that utilizes MEMS gyroscope for counting the output signal half-period number. In addition, the results show that the accuracy (scale factor stability) does not depend on switch-on conditions (with or without FOG rotation at the moment of switching).

Figure 9 shows the results of SRS-1001 angular rate measurement error calculation in run-to-run stability tests at rotation rate 100 °/s; devices were switched on in rotation. These results show that the scale factor stability values are almost equal for the cases of single launch tests and run-to-run tests.

The results of FOG SRS-1001 bias and temperature drift stability tests at stable temperatures +20°C, -30°C and +60°C, and also in conditions of gradual temperature change in range -30°C - +60°C have shown that SRS-1001 devices with extended dynamic range up to 550°/s retain all accuracy parameters of FOG SRS-1000.

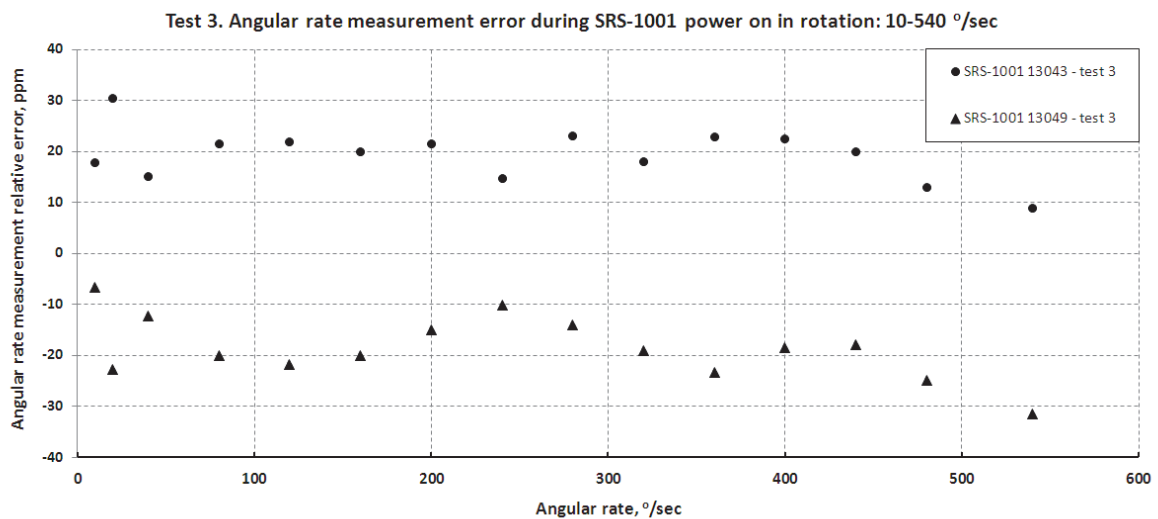

Fig. 8. SRS-1001 angular rate measurement error in tests with switching on in rotation

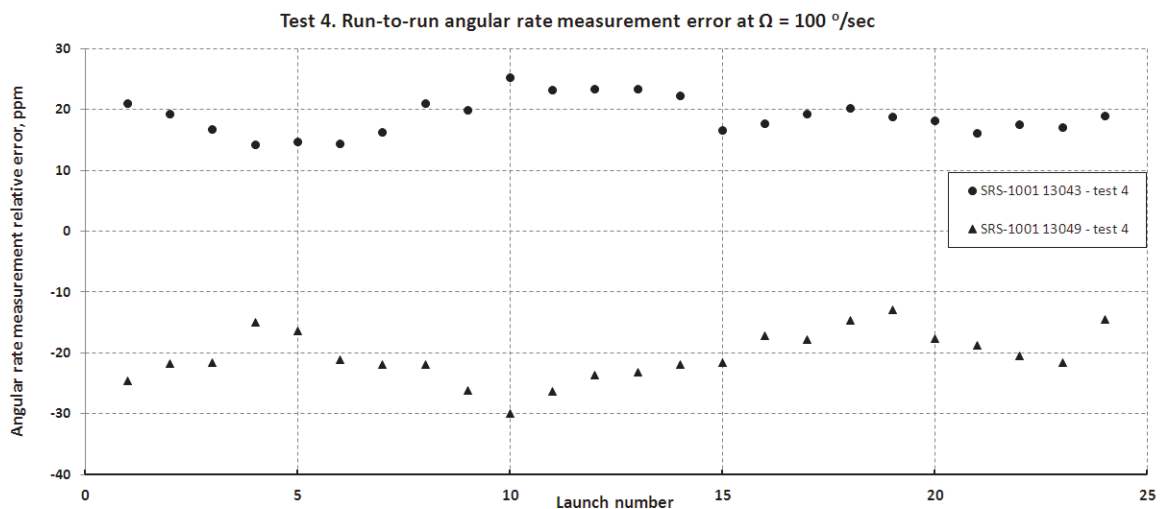

Fig. 9. SRS-1001 run-to-run angular rate measurement error at rotation rate 100°/s

Final accuracy and operational characteristics (specification) of developed high-precision fiber-optic gyroscope SRS-1001 with extended dynamic range are summarized in the Table.

**Accuracy and operational characteristics of high-precision fiber-optic gyroscope SRS-1001 with extended dynamic range**

Parameter	Single axis FOG SRS-1001
Range of measured angular rate, °/s	±550
Bias drift at fixed temperature, °/h	0.01
Scale factor repeatability, ppm	200
Bandwidth, Hz:	100
Random walk, °/√h	0.0005
Weight, kg	0.8
Dimensions, mm	Ø150x80
Output signal	RS-485

Fig. 10 presents the image of produced and tested for accuracy parameters FOG SRS-1001 with extended dynamic range.

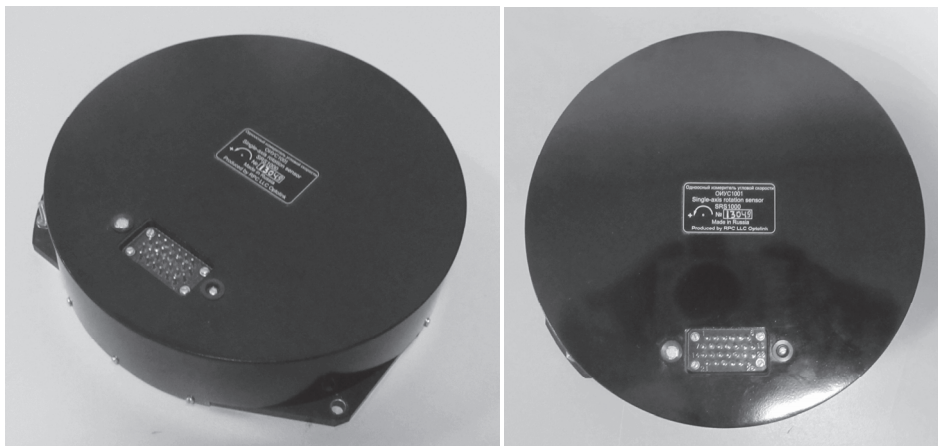

Fig.10. Image of FOG SRS-1001 with extended dynamic range

Hence, company LLC RPC “Optolink” has developed and prepared for serial production the new high-precision fiber-optic gyro with extended range of measured angular rates, which displays high stability of scale factor in overall measurement range.

#### References

1. **Lefevre H.**, The Fiber-Optic Gyroscope, Artech House, 1993.
2. Optical fiber rotation sensing, edited by **W.K.Burns**, Academic press, 1994.
3. **Yu.N.Korkishko, V.A.Fedorov, S.M.Kostritskii, A.N.Alkaev, E.M. Paderin, E.I.Maslennikov, D.V.Apraksin.** Multifunctional integrated optical chip for fiber optical gyroscope fabricated by high temperature proton exchange // in Proceedings of SPIE, Vol.4944, Integrated Optical Devices: Fabrication and Testing, edited by Giancarlo C. Righini, (SPIE, Bellingham, WA, 2003), pp. 262-267.

4. **Коркишко Ю.Н., Федоров В.А., Прилуцкий В.Е., Пономарев В.Г., Фенюк М.А., Марчук В.Г., Кострицкий С.М., Падерин Е.М.**, Высокоточный волоконно-оптический гироскоп с линейным цифровым, // Гироскопия и навигация, 2004. N1 - С.69-82.
5. **Прилуцкий В.Е., Пономарев В.Г., Марчук В.Г., Фенюк М.А., Коркишко Ю.Н., Федоров В.А., Кострицкий С.М., Падерин Е.М., Зуев А.И.**, Интерферометрические волоконно-оптические гироскопы с линейным выходом // Гироскопия и навигация, 2004. N3 - С.62-72.
6. **Yu.N. Korkishko, V.A. Fedorov, V.E. Prilutskii, V.G. Ponomarev, V.G. Marchuk, I.V. Morev, E.M. Paderin, S.M. Kostritskii, V.N. Branets, V.S. Ryzhkov.** Space grade three-axis fiber optical gyroscope // in Proc. EOS Topical Meeting on Photonic Devices in Space, October 18-19, 2006, Paris, France. Vol.5, pp.32-35.
7. **Коркишко Ю.Н., Федоров В.А., Прилуцкий В.Е., Пономарев В.Г., Морев И.В., Марчук В.Г., Кострицкий С.М., Падерин Е.М.** Интерферометрические волоконно-оптические гироскопы // Фотон-Экспресс, 2007, 6(62), с. 47-49.
8. **Коркишко Ю.Н., Федоров В.А., Прилуцкий В.Е., Пономарев В.Г., Марчук В.Г., Морев И.В., Кострицкий С.М., Падерин Е.М., Несенюк Л.П., Буравлев А.С., Лисин Л.Г.** Волоконно-оптический гироскоп навигационного класса точности // Гироскопия и навигация, 2008, № 1, с.71-81.
9. **Yu.N. Korkishko, V.A. Fedorov, V.E. Prilutskii, V.G. Ponomarev, I.V. Morev, S.M. Kostritskii.** Interferometric closed-loop fiber-optic gyroscopes // in Proceedings of SPIE, Vol.8351, Third Asia Pacific Optical Sensors Conference, edited by John Canning, Gangding Peng, (SPIE, Bellingham, WA, 2012), 83513L, pp. 83513L-1–83513L-8 (2012).
10. **Yu.Korkishko, V.Fedorov, V.Prilutskii, V.Ponomarev, I.Morev, S. Kostritskii, A.Zuev, V.Varnakov.** Closed loop fiber optical gyroscopes for commercial and space applications // in Proc. Inertial Sensors and Systems - Symposium Gyro Technology 2012, Karlsruhe, Germany, 18-19 September 2012, p.14.1-14.15.
11. **Yu.N.Korkishko, V.A.Fedorov, V.E.Prilutskii, V.G.Ponomarev, I.V.Morev, S.M.Kostritskii, A.I.Zuev, V.K.Varnakov.** Interferometric closed loop fiber optical gyroscopes for commercial and space applications // in Proceedings of SPIE, Vol.8421, OFS2012 22nd International Conference on Optical Fiber Sensors, edited by Yanbiao Liao, Wei Jin, David D. Sampson, Ryozo Yamauchi, Youngjoo Chung, Kentaro Nakamura, Yunjiang Rao, (SPIE, Bellingham, WA, 2012), 842107, pp. 842107-1–842107-8 (2012).